

Instructions MANUAL

Folding kayak NERIS-2 (tandem)

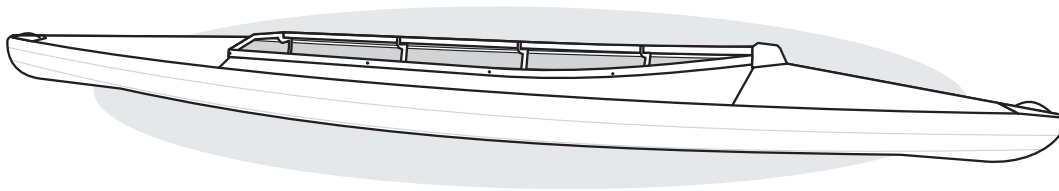

1. General description



NERIS-2 is a touring folding kayak ideal for flat water trips on rivers, lakes and water reservoirs. It is also suitable for sea and ocean kayaking along shore line.

The light weight and high compatibility are the main advantages of the NERIS folding kayak providing paddlers ease in transporting and use.

The kayak assembly and disassembly time is within 20-25 minutes. No additional tools are required. The framing of the kayak provides required stiffness and shape to have great paddling experience.

Technical features:

Loading capacity	300 kg
Length	5,5 m
Width	0,84 m
Weight	27 kg

Packaging size:

back pack (mm)	500 x 900 x 230
long pack (mm)	1500 x 240 x 240

Kayak capacity:

recreational trips:	2 adults + 1 child
touring expedition:	2 adults

2. Bags' Content

1. Set of crossribs - 7 psc.
2. Bow and Stern Assembly
3. Bow and Stern A-shape Keelbars
4. Set of Stringers:
 - a - dual stringer plates - 4 psc
 - b - single stringers - 4 psc
5. Set of Washboards - 4 psc.
6. Skin
7. Back pack and Long pack
8. Repair Kit

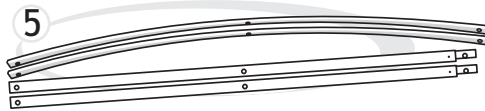
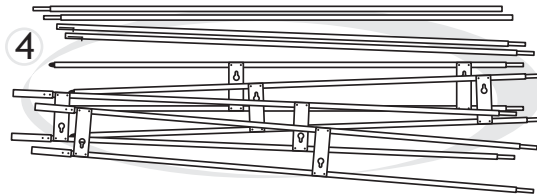
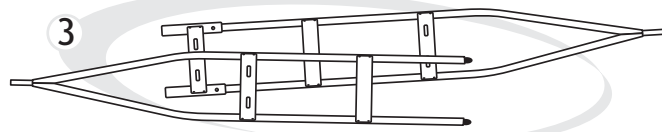
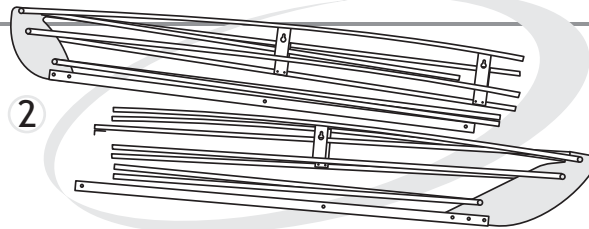
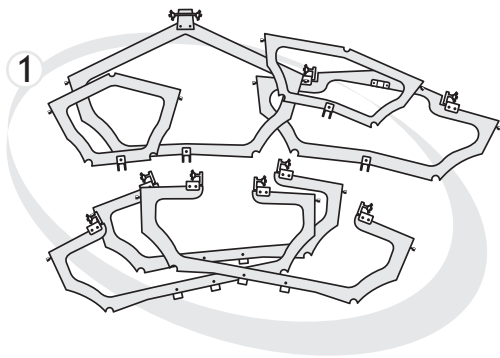

3. Assembly Instructions



All NERIS folding kayaks are run through presale test assembly. However, the first kayak assembly may seem to be more challenging than following one. The skin is being stretched with each assembly and it will be easier to put the skin on a frame.

Two people kayak assembly is recommended. The kayak is to be assembled on even and clean surface. Avoid assembling the kayak on sand. It may cause damage to joining parts and more difficult assembly and disassembly in future.

The main parts of the kayak are marked with numbers and pointing arrows for ease of assembly.

Marking points:

- LB - Bow, Left
- LS - Stern, Left
- RB - Bow, Right
- RS - Stern, Right

Step 1.

Attach Crossrib #1 to Bow Assembly as marked with two arrows pointing each other. Use a wing nut and bolt to secure the crossrib.

Repeat this step for stern assembly using Crossrib #7.

The Assembly upper and middle stringers are connected by plates with keyhole slots to be secured on sides of Crossribs #1 and #7.

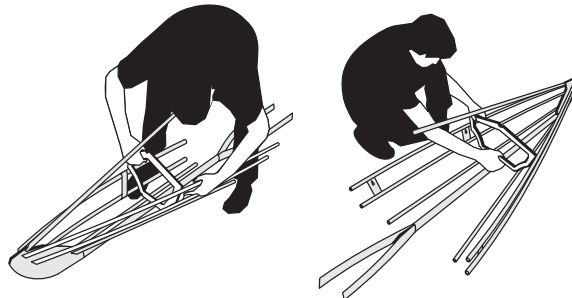

3. Assembly instructions

Step 2.

Attach A-Shape Keelbars to Bow and Stern Assembly, positioning holes to see through.

Position the Crossrib #2 with a bracket meeting the bar hole and secure it with a bolt and wing nut. Repeat this step for attaching the Crossrib #6 to Stern Assembly.

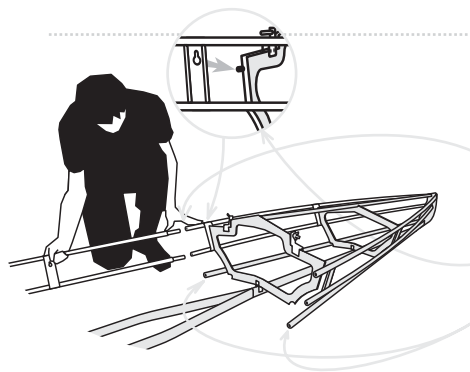
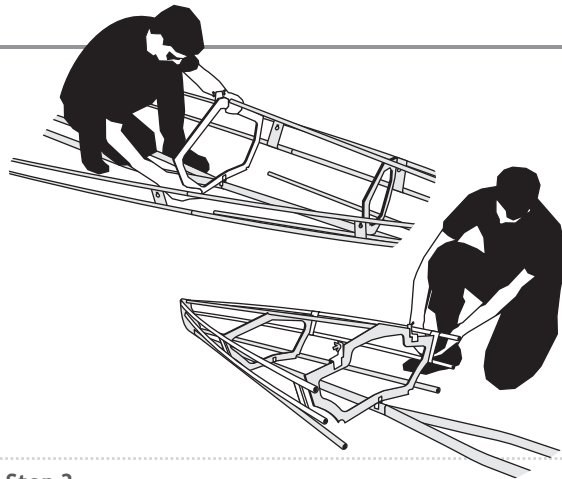

Step 3.

Extend left and right dual stringer plates marked **LB** and **RB** to Bow Assembly. Repeat this step for Stern Assembly and stringer plates marked **LS** and **RS**.

Secure Crossribs # 2 and #6 in stringer keyhole plate slots.

Insert low stringers to bow and stern sections.

The bow and stern sections are ready to be inserted in to the skin.

3. Assembly instructions



Step 4.

Unroll the skin. Insert bow and stern assembly sections into the skin. Make sure that the stitch line between deck and hull is positioned just above the upper stringer.

Frame parts should be inserted into the skin without visible distortion!

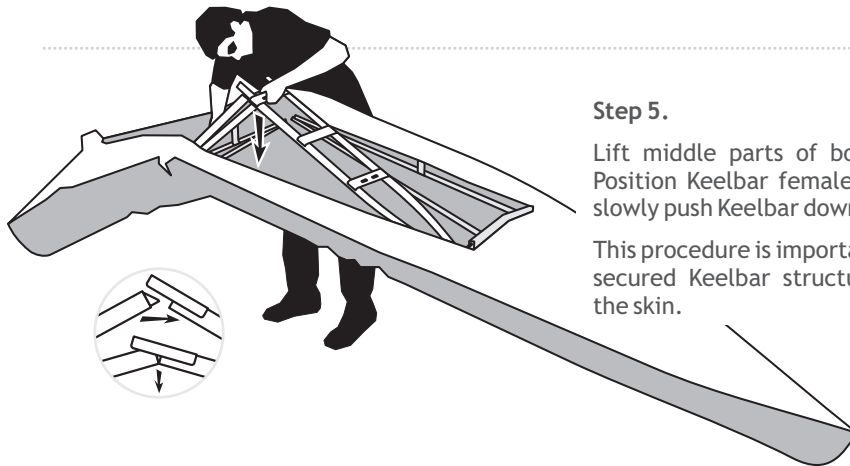

Step 5.

Lift middle parts of bow and stern sections. Position Keelbar female and male sleeves and slowly push Keelbar down.

This procedure is important to ensure the proper secured Keelbar structure fore-and-aft inside the skin.

3. Assembly instructions

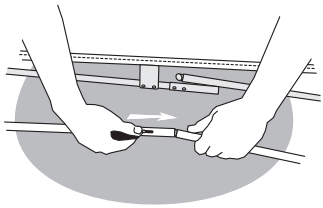

Step 6.

Take lower single stringers lifting them up. Pull spring latch aside and center both stringers. Release latch slowly while strengthening Stringers.

Secure dual stringer plates by pulling upper and middle gunwales inside the kayak. Position stringers in female and male sleeves and slowly release the connected stringers towards the skin.

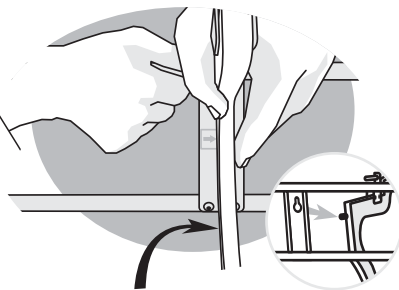
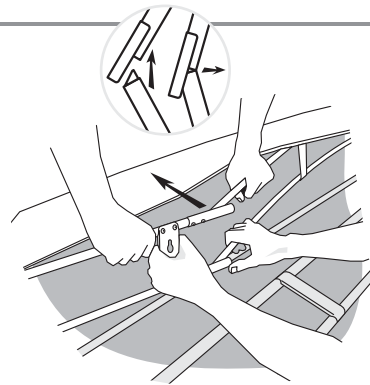

Step 7.

Position Crossribs ## 3,4,5 on Keelbar as marked by pointed arrows.

Secure the Crossribs on dual stringers plates by lifting the plates slightly and inserting the side knob through the keyhole plate slots.

3. Assembly instructions

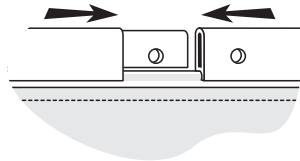
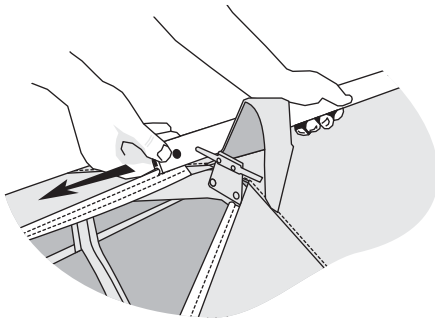

Step 8.

Install the washboards. Before installing the washboards replace the wing nuts from U-bolts on Crossribs. Insert the round rope skin edge into the open end of the grooved channel at the bottom of the washboard sections. Engage curved bow section of the washboard from the bow and rear section from the stern. Move both bow and stern sections to the center of the kayak and meet the washboard holes with the U-bolts of Crossribs. Secure the washboard sections by wing nuts. Make sure the first and last washboard holes are secured first. Then proceed with other sections.

Two people are recommended to complete this step. The first person pulls the washboard in place. The other person puts the wing nut on.

When all wing nuts are in place tight them up securely.

3. Assembly instructions

Step 9.

The front seat is to be installed between Crossribs #3 and #4. The rear seat is positioned between Crossribs #5 and #6. Strap the lower part of the seat over the Crossrib just above the lower stringer. The back seat is to be strapped through U-bolt of the Crossrib.

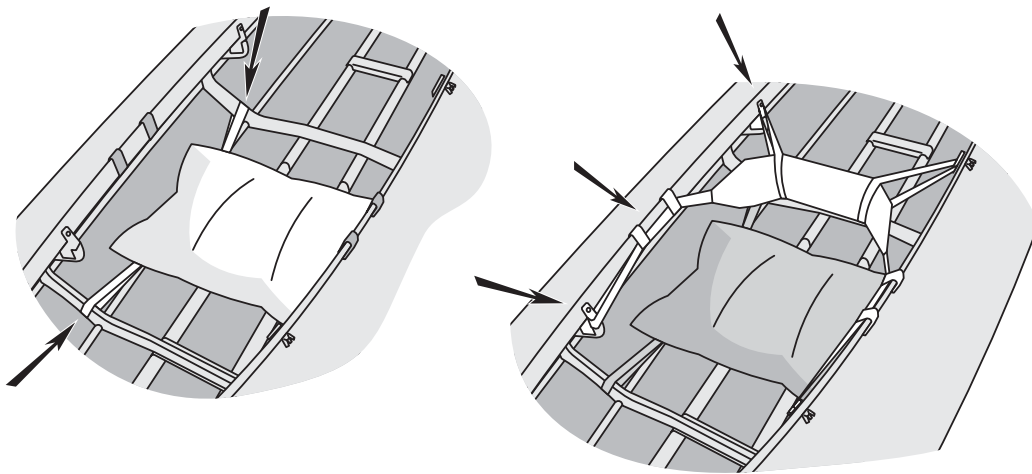

The kayak is ready to go!

4. Additional Information.



Unfolded kayak packaging.

To ensure long life of the folding kayak the proper packaging is required. When the skin is free of the frame remove dirt, grit and other objects. Spread the skin and dry out. Follow the steps on the diagram below to pack the skin and Crossribs. Include the seats, repair kit and other accessories as spray deck and skirts in the backpack in addition to the skin. All long parts of the kayak are to be placed in the long pack.

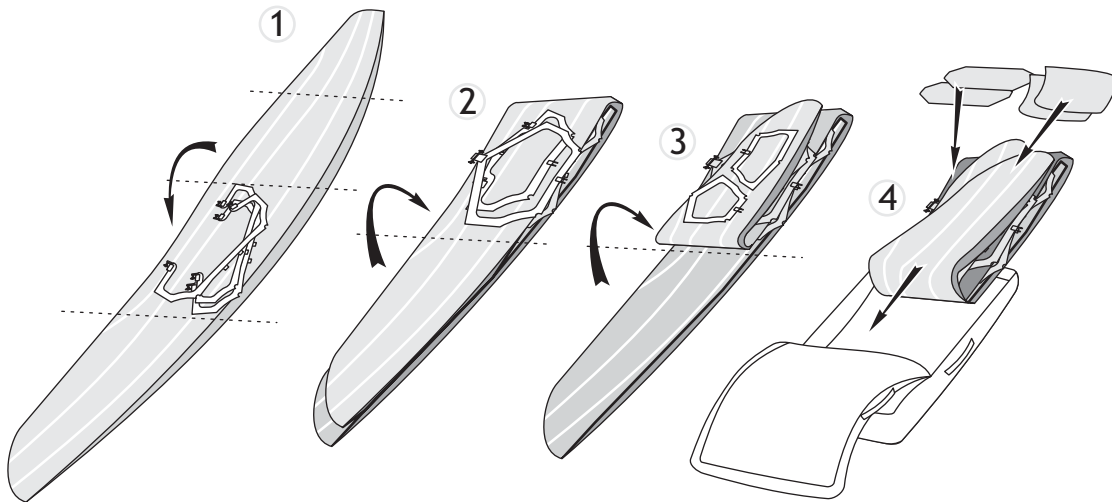

4. Additional Information



Storage and maintenance of the kayak.

When done paddling ensure that Crossribs and Skin are dried out. If used on sea waters, all parts of the kayak must be rinsed off with fresh water.

It is recommended to store the kayak inside the dry and warm conditions. This is a requirement for Crossribs mainly. The Skin and other aluminium parts can be stored either on balcony or in garage and/or locker.

It is not desirable to move the skin while storing it at low temperatures.

For longer life the Crossribs can be varnished with a marine grade varnish at the end of the kayaking season. Follow instructions of varnish manufacturer.

Skin repair instructions can be found on line www.neris.ua in FAQ.

Manufacturer's Warrantee.

NERIS LTD. - the manufacturer guarantees suitability and kayak material quality under condition that the assembly instructions have been followed. The manufacturing company will repair free within 36 months of use from the date of purchase should there be manufacturer's defects. You also can address any repair issues as a result of hitting rocks or wrong assembly during warrantee periods and later. However, kayak owner will bear the repair costs.

Contact us.

Contact NERIS Ltd. for any suggestions and questions not revealed in this instructions manual.

.....
Kayak serial number:
Date manufactured:

NERIS Ltd, President

Konstantin Abramov



NERIS Ltd. , Ukraine, Kiev region, Vyshgorod area,
Starie Petrovtsy Village, Bukaevitsa, 2.
Tel.: (+380-44) 228-0-228
E-mail: info@neriskayaks.com
Website: www.neriskayaks.com

